

The **CL 6587.103** triple input analyzer belongs to the latest series of instruments developed by B&C Electronics. The instrument includes our 40 years' experience and knowledge in the measurement and control of residual chlorine, pH and ORP.

The pH, ORP and temperature sensors in our catalog allow the simultaneous display of these measures in addition to the fourth value provided by one of the sensors of the main oxidizing substances, such as residual free chlorine, combined and total chlorine, chlorine dioxide, dissolved ozone, hydrogen peroxide and peracetic acid, which are compatible with the analyzer. All these possible solutions make the controller suitable for virtually any application and type of sample.

Main features

Range

0 ÷ 200.0 ppb / µg/l
 0 ÷ 2.000 ppm / mg/l
 0 ÷ 20.00 ppm / mg/l
 0 ÷ 200.0 ppm / mg/l
 0 ÷ 2000 ppm / mg/l
 0 ÷ 14.00 pH
 -2000 ÷ 2000 mV
 -10.0 ÷ 110.0 °C, 14.0 ÷ 230.0 °F

Configuration

Default configuration is for residual chlorine, pH and ORP measurements. However, the controller can easily be configured for chlorine-pH-pH or chlorine-ORP-ORP.

pH compensation

The measurement of free chlorine can be automatically compensated with respect to the pH variations measured by the connected pH sensor or by a 4-20 mA signal from an external pH meter. The compensation is carried out using an internal table, that can be edited according to the actual conditions of each installation.

Display

The multi-line graphic display shows the values of the measures and the messages which guide the user through set-up, configuration and during normal operation.

Keyboard

There are dedicated keys to directly access zero and sensitivity calibration as well as set point configuration.

Operating mode

The meters can operate in automatic, measure or simulated mode so to facilitate start-up or maintenance.

Two filters software

The user can set two filters in order to obtain a stable reading and a faster response to the variations of the measurement in the process.

Two analog outputs

Can be addressed to any input and programmable 0/4 – 20 mA on two points of the scale. They allow PID control or transmission of the measured values.



Digital output

RS485 isolated output, with protocols B&C ASCII and MODBUS RTU (function 03).

Two On/Off regulators

Independent and addressable to any input with programmable set point on the scale.

PID output

During PID control through the analog output, the level of the actuation is displayed.

The user can select an FM regulation (pulse frequency) or WM (pulse width) addressed to the assigned relay.

Alarm

The relay is dedicated to min/max values of the measures, the excessive activation of relays and the presence of the logic inputs.

Alternatively, this relay can be addressed and dedicated to the control function.

Logic inputs

Two free voltage contacts can generate a hold or alarm condition.

Autocleaning

A relay is dedicated to an external device for the sensor self-cleaning. This function is fully programmable through the controllers' software. Alternatively, this relay can be addressed and dedicated to the control function.

Universal power supply

From 85 to 264 Vac, 50/60 Hz.

The low voltage option allows to power the unit from 9 to 36 Vdc or from 12 to 24 Vac, 50/60 Hz.

Easy installation

All 6587 series of controllers have IP65 protection rating. They are suitable for wall mounting, or for DIN rail and handrail by means of optional accessories.

Compatible and versatile

The analyzer is compatible with pH and ORP sensors, and with any amperometric sensor (polarographic or potentiostatic) with two or three electrodes.

The temperature measuring and compensation is done with Pt100 or Pt1000 two or three wires probes.

Applications

- Aquaculture
- Chemical industry
- Drinking water
- Fertirrigation
- Food and beverage
- Pharmaceutical
- Textile industry
- Water treatment
- Swimming pools

Technical specifications

Inputs:	potentiostatic sensors polarographic membraned sensors pH electrodes (glass/antimony) ORP Pt100 / Pt1000
Zero:	± 20%, ± 5.0 °C, ± 9°F
Sensitivity:	12.5 ÷ 250 %
Resolution:	1 digit
Accuracy:	0.2 %
Repeatability:	0.1 %
Non linearity:	0.1 %
Dual filter software:	0.4 ÷ 50.0 seconds for small and large variations
Dual analog output:	0-20 mA / 4-20 mA Rmax 600 Ω
Digital output:	RS485 isolated, protocol B&C ASCII and MODBUS (function 03)
Dual set point HI/LO:	ON/OFF - PID - PFM - PWM, SPST relays
Hysteresis:	0 ÷ 10 %
Delay:	0 ÷ 100.0 seconds
Alarm:	SPDT relay with delay 0 ÷ 100.0 seconds
Cleaning function:	off / autoclean / manual, relay SPDT repetition time 0.1 ÷ 100.0 hours cleaning time 1.0 ÷ 60.0 seconds holding time 0.0 ÷ 20.0 minutes
SPST and SPDT relay contacts:	220V - 5 A resistive load
Operating temperature:	-10 ÷ 60 °C
Humidity:	95% without condensation
Power supply:	85 ÷ 264Vac - 50/60 Hz 9 ÷ 36Vdc, 12 ÷ 24Vac (option 091.42x)
Terminal blocks:	removable
Weight:	1360 g
Enclosure:	ABS, IP 65 protection
Dimensions:	256x230x89 mm
EMC/RFI conformity:	EN 61326
Registered design:	002564666-002

The technical specifications could be changed without notice.

Dimensions and installation

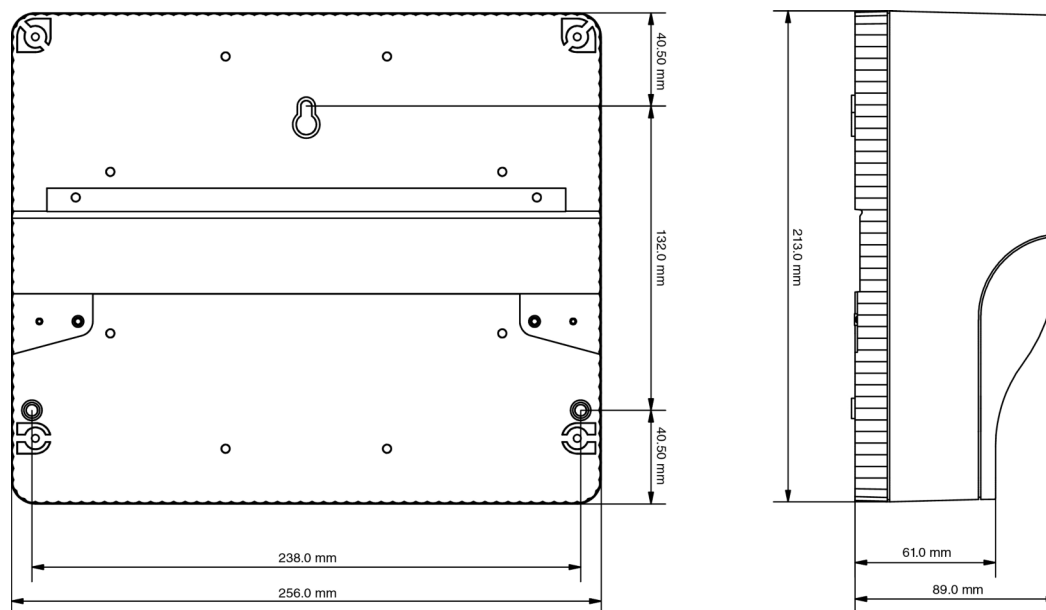

Wall

DIN rail

Handrail

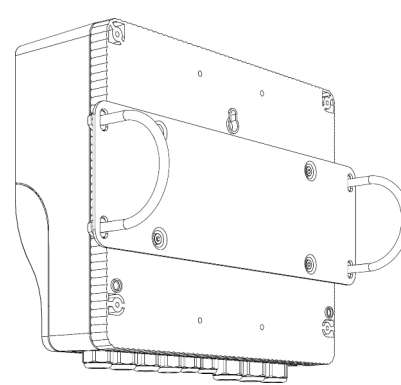
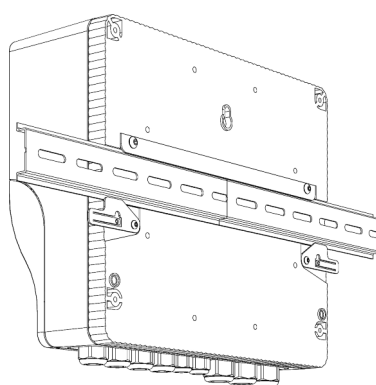
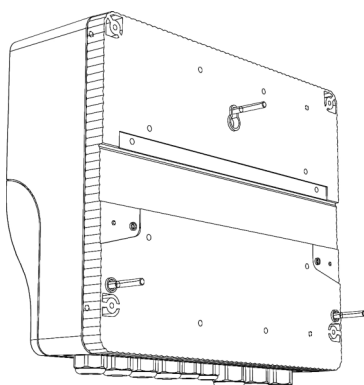

Standard configuration

Our Sales Team is available to recommend the most suitable sensors for your specific application.

If **CL 6587.103** is used to measure free residual chlorine, pH and ORP we suggest to use potentiostatic sensor **SZ 283**, which besides being easy to install, it guarantees low maintenance costs and great stability of zero in absence of oxidizing and reducing agents in the measured sample.

To measure pH, the anular junction sensor **SZ 165** fits most applications as well as the ORP sensor **SZ 275** with a larger platinum ring and anular junction.

Together with temperature probe **SP 514**, the three sensors can be placed inside the overflow cell **SZ 7233**, which is designed to compensates any potential flow variations that are within the range of flow specified.

